

Autopilot Tiller Arm Data Sheet

All Tiller Arms are custom machined and are non-returnable - please measure carefully. Bores are machined to $+.003$ tolerance, so the use of a micrometer is highly recommended when measuring.

See current Edson price page for machining charges on special or square bores, keyways or setscrews.

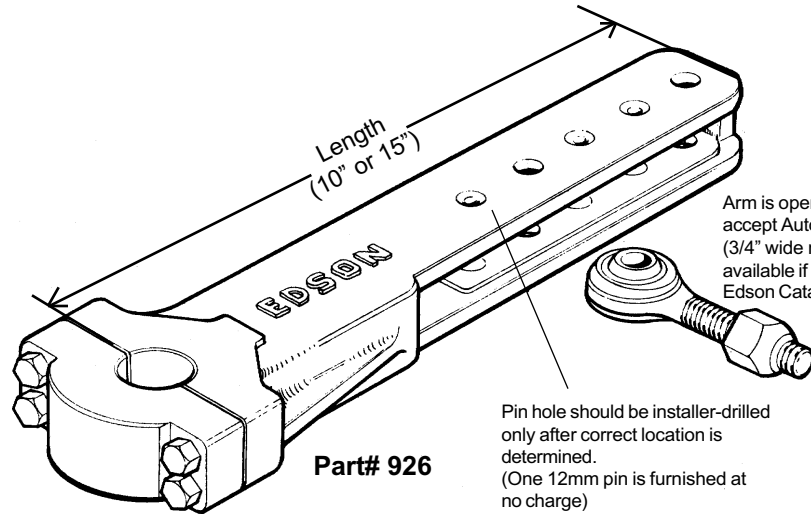

Company Name: _____	Customer Name: _____
Boat Type/Model: _____	Length: _____
Year: _____	
Bore Size : _____	Specify: Key _____ Through-Bolt _____ Set Screws _____
If key required, specify size: _____ Length of Arm:(10" or 15") _____	

Sketch Location of Tiller Arm and Autopilot

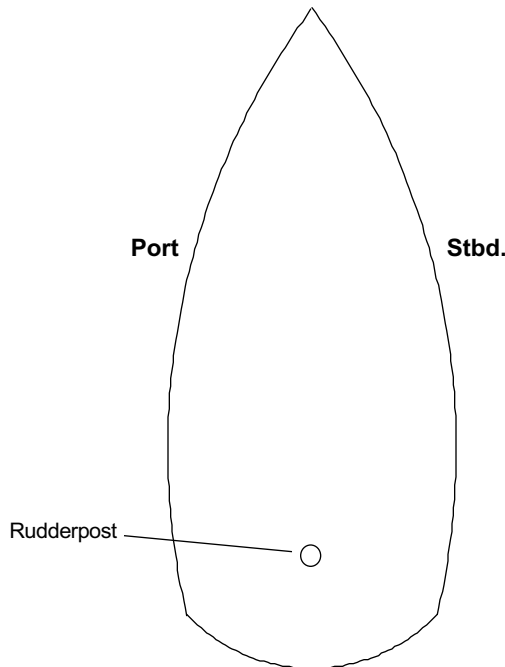

Mark the location of the keyway on the diagram below if it differs from the standard location*.

